

DUMBBELL ADJUSTMENT GUIDE

FOR SMOOTH & ACCURATE WEIGHT PLATE SELECTION

STEPS TO RESOLVE THE FOLLOWING

- + Selector dial will not push down and lock into place.
- + Selector dial feels tight or will not turn easily.
- + Extra weight plate sticks when the Vario Select Dumbbell Handset is removed from Cradle.
- + Weight plates are too widely spaced or too closely spaced.

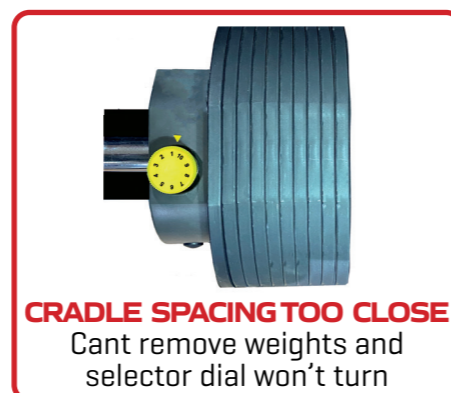
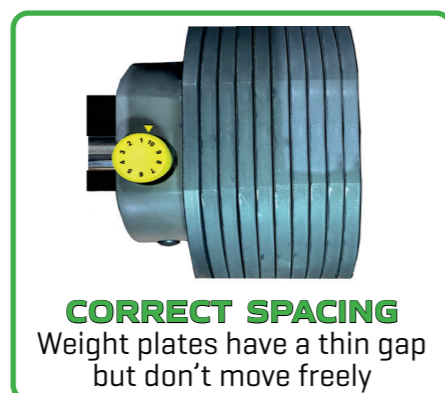
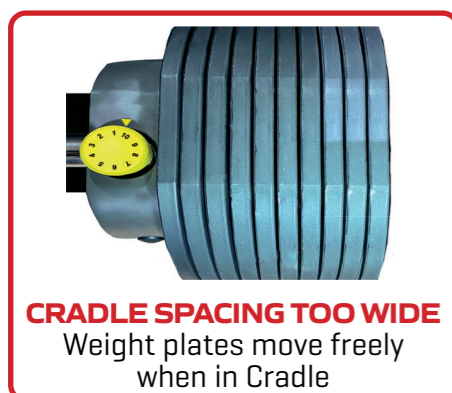

STEP ONE

With the Dumbbell Handset still in Cradle, locate adjustments bolts in the slots underneath Cradle.

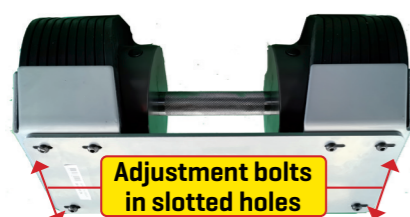

STEP TWO

Using a M4 Allen Key loosen the 4 Adjustment Bolts at one end of the Vario System Dumbbell Cradle just enough to allow you to move the Cradle as required.



IF CRADLE SPACING TOO WIDE

Push the floating Cradle end slightly inwards. Tighten Bolts and replace Dumbbell Handset and check that the gap between the plates is the correct spacing and test on all dial settings. If not correct, repeat adjustment steps.

IF CRADLE SPACING TOO CLOSE

Move slightly apart the floating Cradle end outwards, opening a slight gap between the plates. Tighten bolts and replace Dumbbell Handset check that the gap between the plates is the correct spacing and test on all dial settings. If not correct, repeat adjustment steps.



VARIO STAND

Made for the Vario Dumbbells Weight Cradles
(with cradle feet removed)

ASSEMBLY & SYSTEM ADJUSTMENTS



USER SAFETY PRECAUTIONS

To avoid possible injury, all users should read and understand these instructions before using any Vario Systems.

1. Consult a medical doctor or healthcare professional to be cleared by them for exercise and to determine the exercises appropriate for you, before undertaking exercise with Vario Select Systems.
2. If you experience any pain or dizziness, stop exercise immediately and consult a medical doctor.
3. Perform any exercise with the correct technique – consult a personal trainer or healthcare professional for guidance if unsure of technique or your personal exercise parameters.
4. Vario Select Systems are designed for home use only and are not suitable or warranted for commercial use.
5. Understand how to select the desired weight with the Vario System, see page 2 following.
6. Never touch the weight selector release button or move the selector dial while the Vario System product is out of the cradle, doing so may release weight plates from the handset and cause catastrophic injury.
7. Never use Vario Systems if they are not functioning properly.
8. Never drop, throw or strike together any Vario System, this will void warranty and could cause permanent damage.
9. Take personal responsibility to ensure your safety and the safety of those around you while using and storing Vario Systems.
10. This appliance can be used by children aged from 14 years and above and persons with reduced physical, sensory or mental capabilities or lack of experience and knowledge if they have been given supervision or instruction concerning use of the appliance in a safe way and understand the hazards involved. Children shall not play with the appliance. Cleaning and user maintenance shall not be made by children without supervision.

US PATENT NUMBERS: 9643042 & 10166427 BRITISH PATENT NUMBERS: 2911752 & 2956218
BREVETT PATENT NUMBERS: 502017000140462 & 502019000108103

UPDATED - 21 0721



HOW TO SELECT DESIRED TRAINING WEIGHT

Only adjust the Weight Selector Dial while the Dumbbell is in the Weight Cradle



Adjust both ends of the Dumbbell to your desired training weight.

ASSEMBLY INSTRUCTION - VARIO STAND



STEP ONE Place the Dumbbell Stand box on a flat firm surface with the Up Arrow pointing up. Open the top of the box and remove the Stand Uprights.

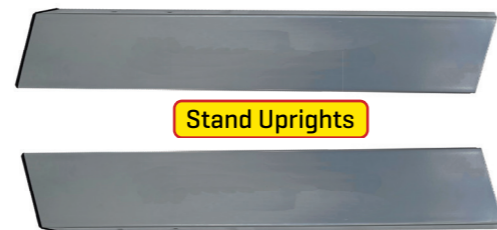

Stand Uprights

STEP TWO The owners guide and hardware kit is visible on the bottom of the box below the Stand Rear Support. Remove the hardware kit from the plastic sleeve and put the Bolts and Allen Keys aside. Remove the Stand Rear Support.



Stand Rear Support

STEP THREE - ASSEMBLE THE STAND

Lay the Stand Uprights on the floor (careful not to damage the floor or stand coating) and place the Stand Rear Support in position to line up the bolt pattern on both parts.

Ensure the KETTLER decal faces outwards on both Stand Uprights and that the Warning decal on the Stand Rear Support will face up when assembled. Attach the Stand Uprights to the Stand Rear Support using 4 Stand bolts with washers - DO NOT fully tighten at this time.

Place Stand assembly on the floor as shown, checking to make sure the Stand assembly sits evenly on the floor. **FULLY TIGHTEN STAND BOLTS.**

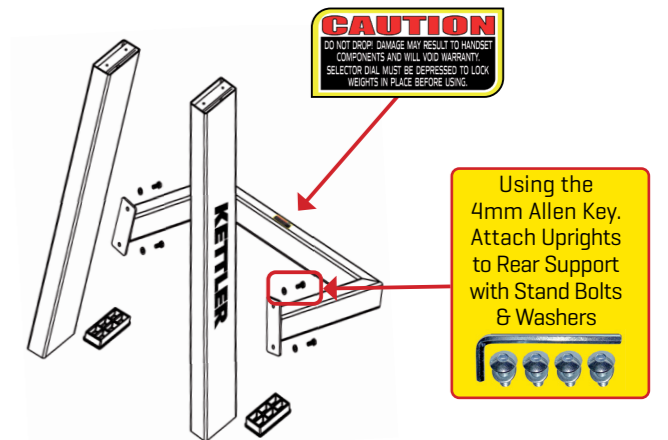

STEP FOUR

If the Vario Select Dumbbell Cradle does not have the Cradle Feet fitted, go to Step 5; otherwise, follow the "How to Select desired training weight" instructions above, and set the dial to 10, remove the Vario Dumbbell Handset from the Cradle and put aside. Setting 10 is the HEAVIEST, so take care when lifting and placing the dumbbell. Turn the Cradle over and, using a 4mm Allen Key remove the Cradle Feet bolts and Cradle Feet.

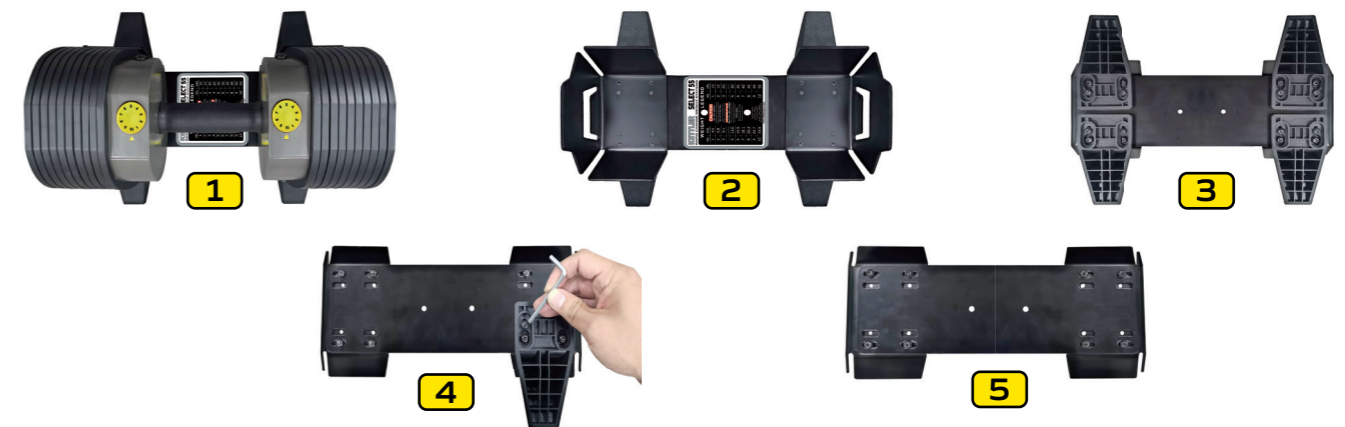

STEP FIVE - ATTACHING THE CRADLES TO THE STAND

Loosely attach one Cradle on top of a Stand Upright using 2 of the Cradle Countersunk Bolts making sure the Weight Legend can be read from the front. Repeat with the other Cradle. Tighten all bolts making sure the Cradles stay parallel.

